

BalconyDrain

Linear drainage for balconies

Typical Applications

- Balconies
- Terraces
- Patio areas
- Restricted depth areas



A choice of grates including Heelsafe® Anti-Slip

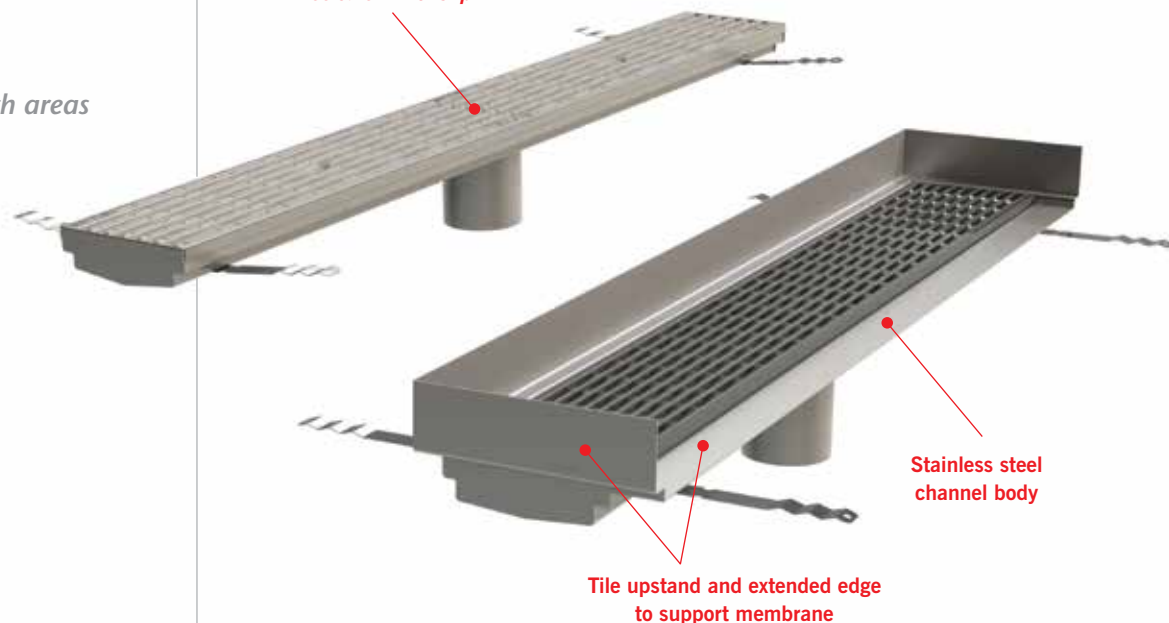

Stainless steel channel body

Tile upstand and extended edge to support membrane



BalconyDrain system

BalconyDrain comprises two systems, dependent on the intended method of installation.

- BD01 – BalconyDrain Standard Edge
- BD02 – BalconyDrain with Flange

BD02 is designed to support the waterproofing membrane and can be customised specific to the drain orientation.



BalconyDrain's range of **Heelsafe® Anti-Slip** grates have raised mechanical nodes and are available in either plastic or stainless steel. Additionally, these are designed to:

- Comply with AS 3996 Clause 3.3.5
- Comply with AS 1428.2 Clause 9(c)
- Resist the penetration of a 10mm heel

A slip resistance classification is assigned to these grates. AS 4586 sets out three recognised tests that determine slip resistance:

- Oil-Wet Inclining Platform test (R-rating)
- Wet Pendulum test (P-rating) and
- Wet Barefoot Inclining Platform test (A,B,C rating)

HB 197 references AS 4586 by specifying the minimum slip resistance ratings suitable for typical applications.

ACO believe that heel friendly grates need to be slip resistant. For more information, visit www.heelsafe.com.au.

Choice of grates including **Heelsafe® Anti-Slip** grates with raised mechanical nodes for slip resistance (rated to AS 4586).

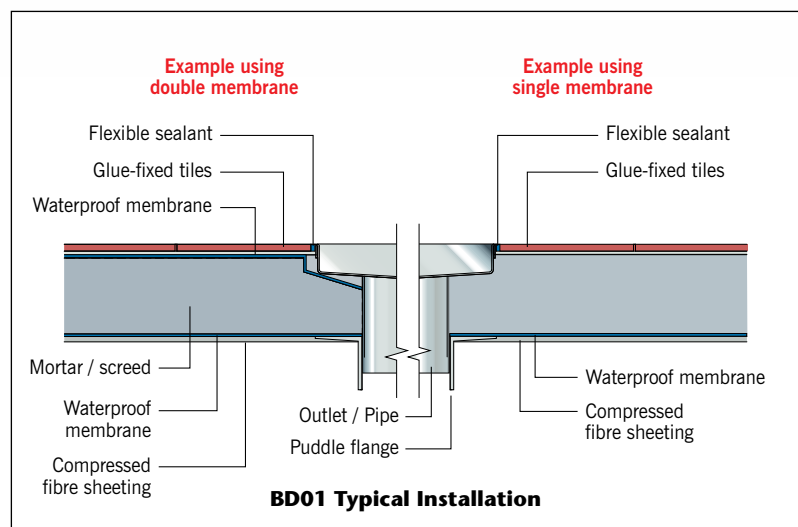
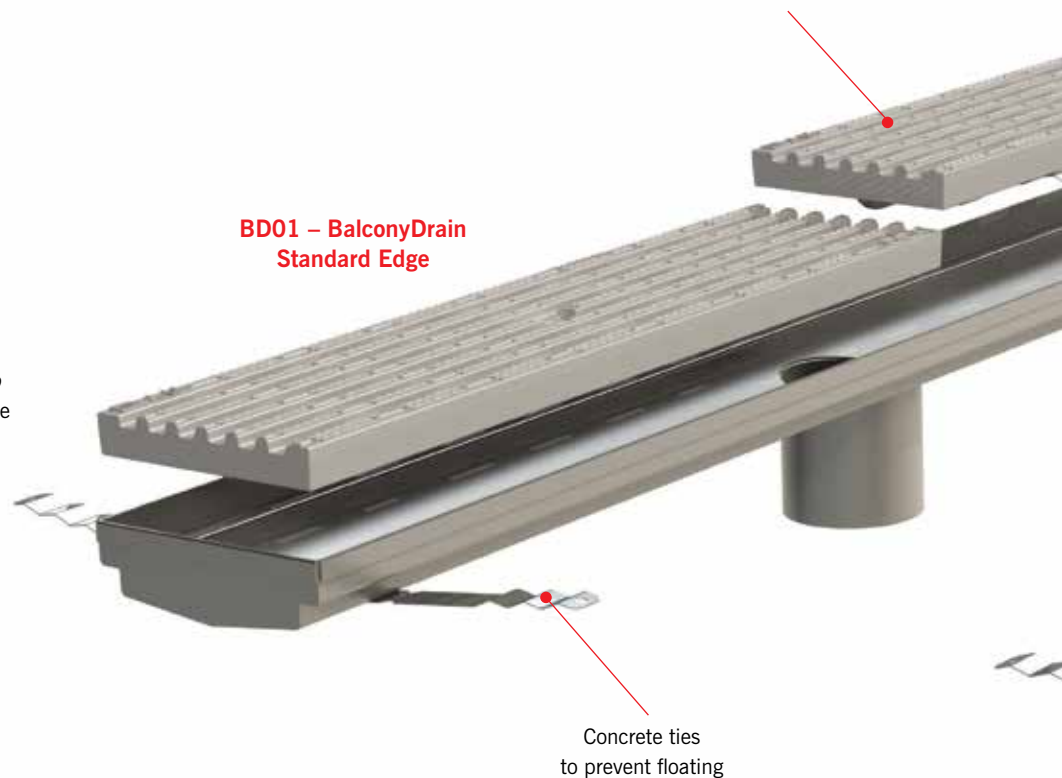

Tile upstand and extended edge – provides membrane flange for waterproofing (reduces reliance on sealants and facilitates a watertight joint). Flange configuration can be customised specific to drain orientation.

BD02 – BalconyDrain with Flange

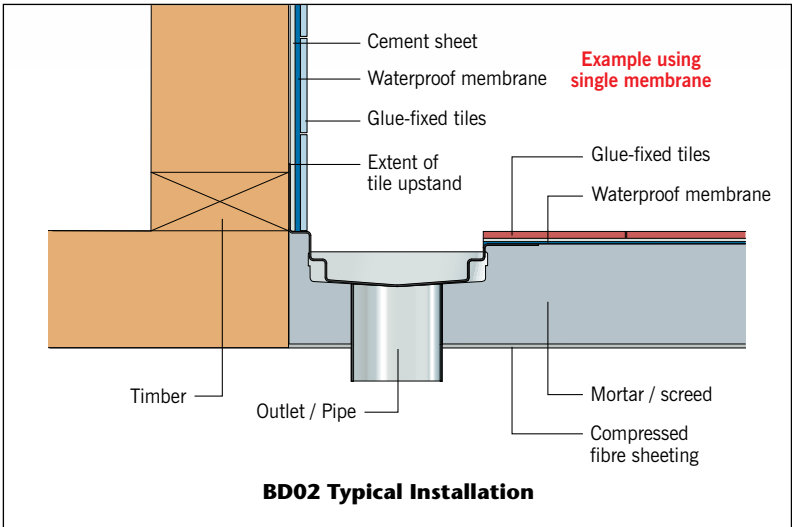
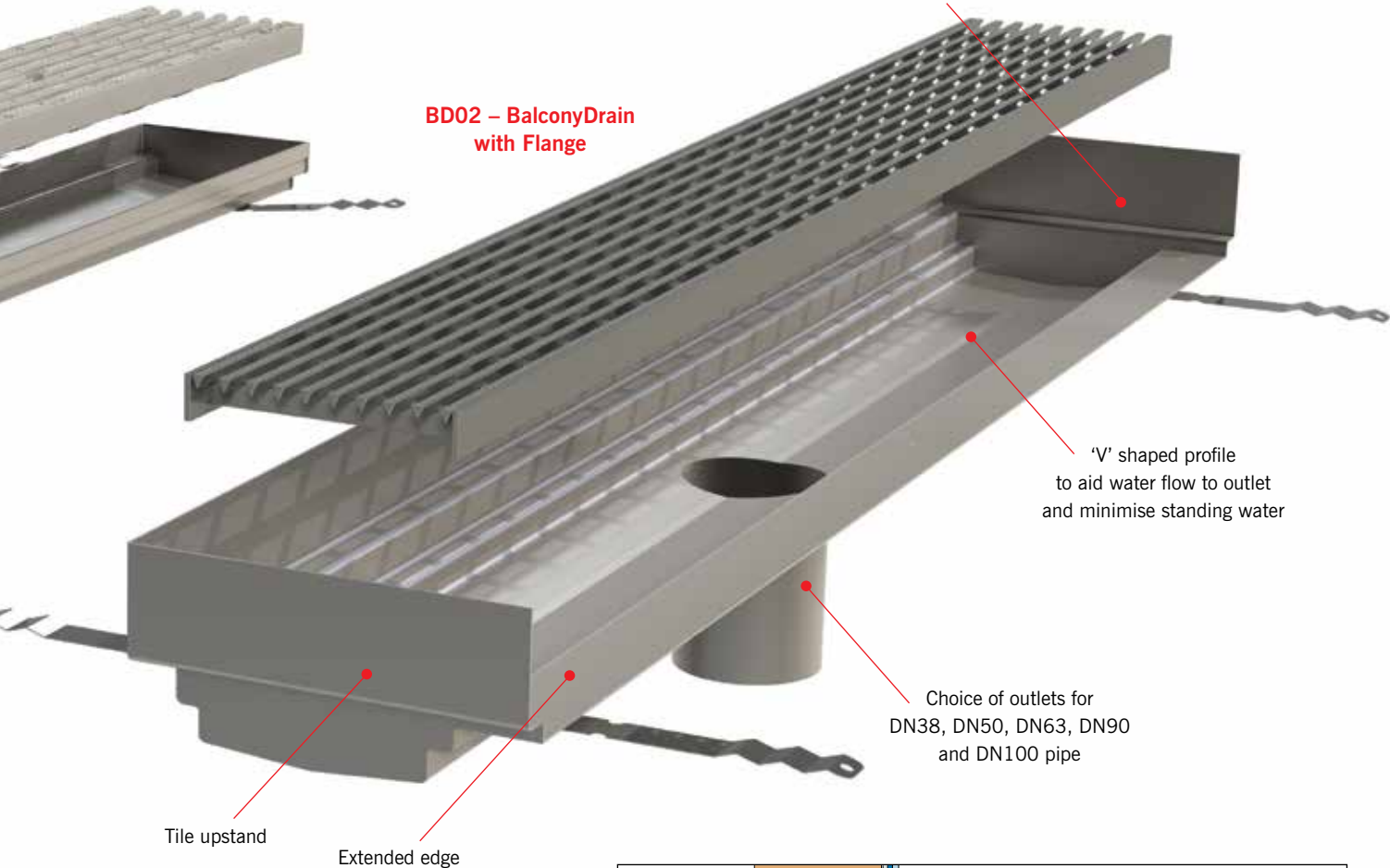

Typical Details

BD01 – BalconyDrain Standard Edge

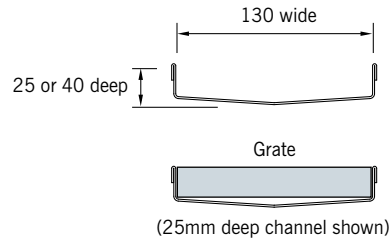
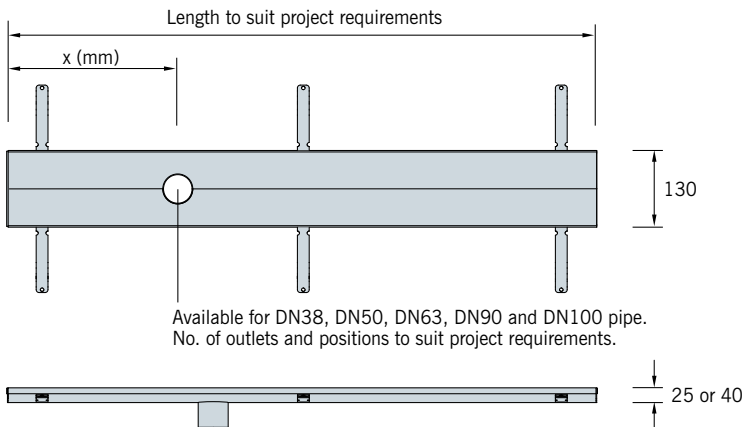

BD02 – BalconyDrain with Flange

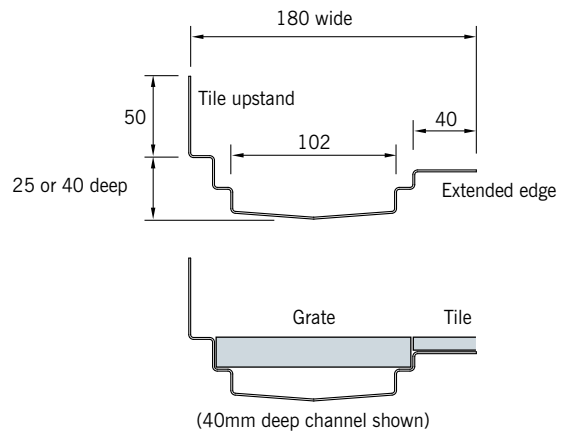
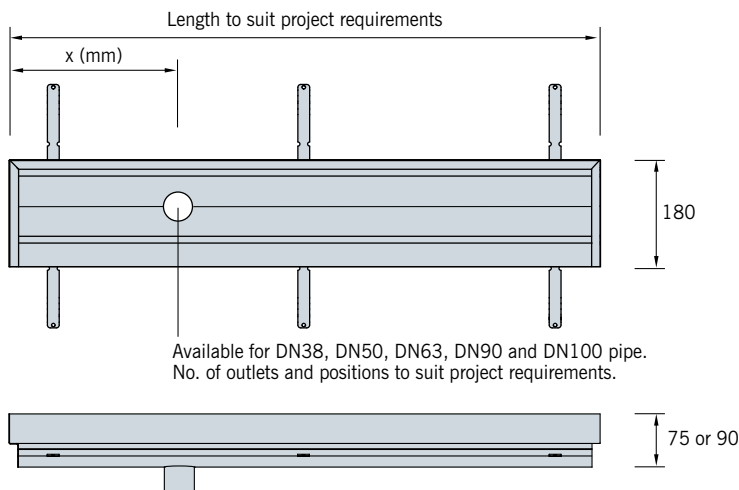

Note: 1. Flange configuration can be customised specific to drain orientation. Contact ACO.
2. All dimensions in mm.

Product Table

Part No.	Description	Length mm	Weight kg	Wheelchair AS 1428.2	Heelsafe (see Pg 2)	Oil Wet Platform ¹	Wet Pendulum ¹	Wet Barefoot Platform ¹
141170	Stainless 5 Star Heelsafe® Anti-Slip Class B	1000	3.2	✓	✓	R9	P4	C
141202	Stainless Wedgewire Heelguard Class A	1000	2.5	✓	✓	–	–	–
142170	Stainless Wedgewire Heelguard Class A 3mm wire, 3mm gap	1000	2.5	✓	✓	–	–	–
97385	Grey Plastic Intercept Heelsafe® Anti-Slip Class A	500	0.8	✓	✓	R9/R10 ²	P3	C/B ²
141500	Stainless Slotted Class A	1000	2.7	✓	–	–	–	–

Notes:

- Rated to AS 4586: Slip Resistance Classification of New Pedestrian Surface Materials.
- Test direction (perpendicular / parallel) relative to grate's length (NATA endorsed test reports available)

ACO Polycrete Pty Ltd

Head Office:

134-140 Old Bathurst Road
Emu Plains NSW 2750
Tel: 1300 765 226
+61 2 4747 4000 (International)
Fax: +61 2 4747 4060
Email: sales@acoaus.com.au
Web: www.acoaus.com.au

Branches in: New South Wales/Australian Capital Territory
Victoria/Tasmania
South Australia/Northern Territory
Queensland
Western Australia



Follow us on

